

MEDITSIINILISED MASKID. NÕUDED JA
KATSEMEETODID
(parandatud väljaanne 07.2019)

Medical face masks - Requirements and test methods
(corrected version 07.2019)

EESTI STANDARDI EESSÕNA

NATIONAL FOREWORD

See Eesti standard EVS-EN 14683:2019 sisaldab Euroopa standardi EN 14683:2019+AC:2019 ingliskeelset teksti.	This Estonian standard EVS-EN 14683:2019 consists of the English text of the European standard EN 14683:2019+AC:2019.
Standard on jõustunud sellekohase teate avaldamisega EVS Teatajas	This standard has been endorsed with a notification published in the official bulletin of the Estonian Centre for Standardisation.
Euroopa standardimisorganisatsioonid on teinud Euroopa standardi rahvuslikele liikmetele kättesaadavaks 07.08.2019.	Date of Availability of the European standard is 07.08.2019.
Standard on kättesaadav Eesti Standardikeskusest.	The standard is available from the Estonian Centre for Standardisation.

Tagasisidet standardi sisu kohta on võimalik edastada, kasutades EVS-i veebilehel asuvat tagasiside vormi või saates e-kirja meiliaadressile standardiosakond@evs.ee.

ICS 11.140

Standardite reprodutseerimise ja levitamise õigus kuulub Eesti Standardikeskusele

Andmete paljundamine, taastekitamine, kopeerimine, salvestamine elektroonsesse süsteemi või edastamine ükskõik millises vormis või millisel teel ilma Eesti Standardikeskuse kirjaliku loata on keelatud.

Kui Teil on küsimusi standardite autorikaitse kohta, võtke palun ühendust Eesti Standardikeskusega:

Koduleht www.evs.ee; telefon 605 5050; e-post info@evs.ee

The right to reproduce and distribute standards belongs to the Estonian Centre for Standardisation

No part of this publication may be reproduced or utilized in any form or by any means, electronic or mechanical, including photocopying, without a written permission from the Estonian Centre for Standardisation.

If you have any questions about copyright, please contact Estonian Centre for Standardisation:

Homepage www.evs.ee; phone +372 605 5050; e-mail info@evs.ee

ICS 11.140

English Version

Medical face masks - Requirements and test methods

Masques à usage médical - Exigences et méthodes
d'essaiMedizinische Gesichtsmasken - Anforderungen und
Prüfverfahren

This European Standard was approved by CEN on 19 November 2018 and includes Corrigendum AC approved by CEN on 19 November 2018.

CEN members are bound to comply with the CEN/CENELEC Internal Regulations which stipulate the conditions for giving this European Standard the status of a national standard without any alteration. Up-to-date lists and bibliographical references concerning such national standards may be obtained on application to the CEN-CENELEC Management Centre or to any CEN member.

This European Standard exists in three official versions (English, French, German). A version in any other language made by translation under the responsibility of a CEN member into its own language and notified to the CEN-CENELEC Management Centre has the same status as the official versions.

CEN members are the national standards bodies of Austria, Belgium, Bulgaria, Croatia, Cyprus, Czech Republic, Denmark, Estonia, Finland, France, Germany, Greece, Hungary, Iceland, Ireland, Italy, Latvia, Lithuania, Luxembourg, Malta, Netherlands, Norway, Poland, Portugal, Republic of North Macedonia, Romania, Serbia, Slovakia, Slovenia, Spain, Sweden, Switzerland, Turkey and United Kingdom.

EUROPEAN COMMITTEE FOR STANDARDIZATION
COMITÉ EUROPÉEN DE NORMALISATION
EUROPÄISCHES KOMITEE FÜR NORMUNG**CEN-CENELEC Management Centre: Rue de la Science 23, B-1040 Brussels**

Contents

	Page
European foreword.....	4
Introduction	5
1 Scope.....	6
2 Normative references.....	6
3 Terms and definitions	6
4 Classification.....	8
5 Requirements.....	8
5.1 General.....	8
5.1.1 Materials and construction.....	8
5.1.2 Design.....	8
5.2 Performance requirements.....	8
5.2.1 General.....	8
5.2.2 Bacterial filtration efficiency (BFE).....	8
5.2.3 Breathability.....	8
5.2.4 Splash resistance.....	8
5.2.5 Microbial cleanliness (Bioburden)	9
5.2.6 Biocompatibility.....	9
5.2.7 Summary of performance requirements.....	9
6 Marking, labelling and packaging.....	9
Annex A (informative) Information for users.....	11
Annex B (normative) Method for <i>in vitro</i> determination of bacterial filtration efficiency (BFE)	12
B.1 General.....	12
B.2 Principle	12
B.3 Reagents and materials.....	12
B.3.1 General.....	12
B.3.2 Tryptic soy agar	12
B.3.3 Tryptic soy broth.....	12
B.3.4 Peptone water	13
B.3.5 Culture of <i>Staphylococcus aureus</i> ATCC 6538, growing on tryptic soy agar slants.....	13
B.4 Test apparatus.....	13
B.4.1 Six stage cascade impactor, the arrangement is specified in Table B.1.	13
B.4.2 Nebulizer, capable of delivering particles with a mean size of $(3,0 \pm 0,3) \mu\text{m}$ when in contact with the cascade impactor.	13
B.4.3 Aerosol chamber, glass, 600 mm long and 80 mm in external diameter.....	13
B.4.4 Flow meters, capable of measuring a flow rate of 28,3 l/min.....	13
B.4.5 Pressure gauge, capable of measuring a pressure of 35 kPa to an accuracy of ± 1 kPa.	13

B.4.6	Erlenmeyer flasks, 250 ml and 500 ml capacity.....	13
B.4.7	Peristaltic or syringe pump, capable of delivering 0,01 ml/min.....	13
B.4.8	Vacuum pump, capable of maintaining a flow rate of 57 l/min.....	13
B.5	Test specimens	13
B.6	Preparation of bacterial challenge.....	13
B.7	Procedure.....	14
B.8	Calculation of bacterial filtration efficiency (BFE)	15
B.9	Test report	16
	Annex C (normative) Method for determination of breathability (differential pressure)	18
C.1	Principle.....	18
C.2	Test apparatus	19
C.2.1	Mass flow meter(s) capable of measuring an airflow of 8 l/min.....	19
C.2.2	Manometer, a differential manometer (water or digital). Individual manometers can also be used. M1 is for the upstream pressure measurement and M2 is for the downstream pressure measurement.	19
C.2.3	Electric vacuum pump including a pressure buffer tank.....	19
C.2.4	Valve permitting the adjustment of the flow rate.....	19
C.2.5	Sample holder	19
C.3	Test specimens	19
C.4	Procedure.....	20
C.5	Calculation of differential pressure	20
C.6	Test report	20
	Annex D (informative) Microbial cleanliness.....	21
D.1	Sampling	21
D.2	Testing.....	21
	Annex ZA (informative) Relationship between this European Standard and the essential requirements of Directive 93/42/EEC [1993 OJ L 169] aimed to be covered	22
	Bibliography	23

European foreword

This document (EN 14683:2019+AC:2019) has been prepared by Technical Committee CEN/TC 205 “Non-active medical devices”, the secretariat of which is held by DIN.

This European Standard shall be given the status of a national standard, either by publication of an identical text or by endorsement, at the latest by September 2019, and conflicting national standards shall be withdrawn at the latest by September 2019.

Attention is drawn to the possibility that some of the elements of this document may be the subject of patent rights. CEN shall not be held responsible for identifying any or all such patent rights.

This document includes Corrigendum 1 issued by CEN on 7 August 2019.

This document supersedes AC EN 14683:2019 AC.

This document includes the corrigendum 1 which updates a requirement in clause B.7.4.

The start and finish of text introduced or altered by corrigendum is indicated in the text by tags AC AC.

This document has been prepared under a standardization request given to CEN by the European Commission and the European Free Trade Association, and supports essential requirements of EU Directive(s).

For relationship with EU Directive(s), see informative Annex ZA, which is an integral part of this document.

The main changes compared to the previous edition are:

- a) the appropriate method for *in vitro* determination of bacterial filtration efficiency (BFE) provided in Annex B has been updated;
- b) the former deleted note in 5.2.3 on the breathability requirements has been reintroduced as standard text; it provides a recommendation regarding the use of a respiratory protective device;
- c) the performance requirements on the breathability (differential pressure) provided in Table 1 have been increased and the appropriate method for determination provided in Annex C has been completely reviewed;
- d) the determination of the microbial cleanliness (bioburden) has been slightly updated and moved from 5.2.5 to a new informative Annex D.

According to the CEN-CENELEC Internal Regulations, the national standards organisations of the following countries are bound to implement this European Standard: Austria, Belgium, Bulgaria, Croatia, Cyprus, Czech Republic, Denmark, Estonia, Finland, France, Germany, Greece, Hungary, Iceland, Ireland, Italy, Latvia, Lithuania, Luxembourg, Malta, Netherlands, Norway, Poland, Portugal, Republic of Macedonia, Romania, Serbia, Slovakia, Slovenia, Spain, Sweden, Switzerland, Turkey and the United Kingdom.

Introduction

The transmission of infective agents during surgical procedures in operating theatres and other medical settings can occur in several ways. Sources are, for example, the noses and mouths of members of the surgical team. The main intended use of medical face masks is to protect the patient from infective agents and, additionally, in certain circumstances to protect the wearer against splashes of potentially contaminated liquids. Medical face masks may also be intended to be worn by patients and other persons to reduce the risk of spread of infections, particularly in epidemic or pandemic situations.

1 Scope

This document specifies construction, design, performance requirements and test methods for medical face masks intended to limit the transmission of infective agents from staff to patients during surgical procedures and other medical settings with similar requirements. A medical face mask with an appropriate microbial barrier can also be effective in reducing the emission of infective agents from the nose and mouth of an asymptomatic carrier or a patient with clinical symptoms.

This European Standard is not applicable to masks intended exclusively for the personal protection of staff.

NOTE 1 Standards for masks for use as respiratory personal protective equipment are available.

NOTE 2 Annex A provides information for the users of medical face masks.

2 Normative references

The following documents are referred to in the text in such a way that some or all of their content constitutes requirements of this document. For dated references, only the edition cited applies. For undated references, the latest edition of the referenced document (including any amendments) applies.

EN ISO 10993-1:2009, *Biological evaluation of medical devices — Part 1: Evaluation and testing within a risk management process (ISO 10993-1:2009)*

EN ISO 11737-1:2018, *Sterilization of health care products — Microbiological methods — Part 1: Determination of a population of microorganisms on products (ISO 11737-1:2018)*

ISO 22609:2004, *Clothing for protection against infectious agents — Medical face masks — Test method for resistance against penetration by synthetic blood (fixed volume, horizontally projected)*

3 Terms and definitions

For the purposes of this document, the following terms and definitions apply.

ISO and IEC maintain terminological databases for use in standardization at the following addresses:

- IEC Electropedia: available at <http://www.electropedia.org/>
- ISO Online browsing platform: available at <http://www.iso.org/obp>

3.1

aerosol

gaseous suspension of solid and/or liquid particles

3.2

bacterial filtration efficiency

BFE

efficiency of the medical face mask material(s) as a barrier to bacterial penetration

Note 1 to entry: The BFE test method is used to measure the bacterial filtration efficiency (BFE) of medical face mask materials.

3.3

biocompatibility

quality of being accepted in a specific living environment without adverse or unwanted side effects

3.4 cleanliness

freedom from unwanted foreign matter

Note 1 to entry: Such matter can be microorganisms, organic residues or particulate matter.

3.4.1 microbial cleanliness

freedom from population of viable micro-organisms on a product and/or a package

Note 1 to entry: In practical use, microbial cleanliness is often referred to as “bioburden”.

3.5 colony forming unit CFU

unit by which the culturable number of microorganisms is expressed

Note 1 to entry: The culturable number is the number of microorganisms, single cells or aggregates, able to form colonies on a solid nutrient medium.

3.6 differential pressure

air permeability of the mask, measured by determining the difference of pressure across the mask under specific conditions of air flow, temperature and humidity

Note 1 to entry: The differential pressure is an indicator of the “breathability” of the mask.

3.7 filter

material used for mechanical and physical separation or deposition of aerosol particles (liquid or solid) from the inhaled and exhaled air

3.8 infective agent

microorganism that has been shown to cause surgical wound infections or that might cause infection in the patient, members of staff or other

3.9 medical face mask

medical device covering the mouth and nose providing a barrier to minimize the direct transmission of infective agents between staff and patient

Note 1 to entry: Transmission of fluid-borne agents from patients to staff may occur via splashes.

3.10 splash resistance

ability of a medical face mask to withstand penetration of synthetic blood projected at a given pressure

3.11 surgical procedure

surgical intervention penetrating by skin or mucosa, performed by a surgical team under controlled environmental conditions

4 Classification

Medical face masks specified in this European Standard are classified into two types (Type I and Type II) according to bacterial filtration efficiency whereby Type II is further divided according to whether or not the mask is splash resistant. The 'R' signifies splash resistance.

5 Requirements

5.1 General

5.1.1 Materials and construction

The medical face mask is a medical device, generally composed of a filter layer that is placed, bonded or moulded between layers of fabric. The medical face mask shall not disintegrate, split or tear during intended use. In the selection of the filter and layer materials, attention shall be paid to cleanliness.

5.1.2 Design

The medical face mask shall have a means by which it can be fitted closely over the nose, mouth and chin of the wearer and which ensures that the mask fits closely at the sides.

Medical face masks may have different shapes and constructions as well as additional features such as a face shield (to protect the wearer against splashes and droplets) with or without anti-fog function, or a nose bridge (to enhance fit by conforming to the nose contours).

5.2 Performance requirements

5.2.1 General

All tests shall be carried out on finished products or samples cut from finished products.

5.2.2 Bacterial filtration efficiency (BFE)

When tested in accordance with Annex B, the BFE of the medical face mask shall conform to the minimum value given for the relevant type in Table 1.

For thick and rigid masks such as rigid duckbill or cup masks the test method may not be suitable as a proper seal cannot be maintained in the cascade impactor. In these cases, another valid equivalent method shall be used to determine the BFE.

When a mask consists of two or more areas with different characteristics or different layer-composition, each panel or area shall be tested individually. The lowest performing panel or area shall determine the BFE value of the complete mask.

5.2.3 Breathability

When tested in accordance with Annex C, the differential pressure of the medical face mask shall conform to the value given for the relevant type in Table 1.

If the use of a respiratory protective device as face mask is required in an operating theatre and/or other medical settings, it might not fulfil the performance requirements with regard to differential pressure as defined in this European Standard. In such case, the device should fulfil the requirement as specified in the relevant Personal Protective Equipment (PPE) standard(s).

5.2.4 Splash resistance

When tested in accordance with ISO 22609:2004 the resistance of the medical face mask to penetration of splashes of liquid shall conform to the minimum value given for Type IIR in Table 1.

5.2.5 Microbial cleanliness (Bioburden)

When tested according to EN ISO 11737-1:2018 the bioburden of the medical mask shall be ≤ 30 CFU/g tested (see Table 1).

NOTE EN ISO 11737-1:2018 specifies requirements and provides guidance for the enumeration and microbial characterization of the population of viable microorganisms on or in a medical device, component, raw material or package.

To determine the mask's bioburden according to EN ISO 11737-1:2018, refer to the procedure as described in Annex D.

The number of masks that shall be tested is minimum 5 of the same batch/lot.

Other test conditions as described in EN ISO 11737-1:2018 may be applied.

In the test report, indicate the total bioburden per individual mask and based on the mask weight, the total bioburden per gram.

5.2.6 Biocompatibility

According to the definition and classification in EN ISO 10993-1:2009, a medical face mask is a surface device with limited contact. The manufacturer shall complete the evaluation of the medical face mask according to EN ISO 10993-1:2009 and determine the applicable toxicology testing regime. The results of testing should be documented according to the applicable parts of the EN ISO 10993 series. The test results shall be available upon request.

5.2.7 Summary of performance requirements

Table 1 — Performance requirements for medical face masks

Test	Type I ^a	Type II	Type IIR
Bacterial filtration efficiency (BFE), (%)	≥ 95	≥ 98	≥ 98
Differential pressure (Pa/cm ²)	< 40	< 40	< 60
Splash resistance pressure (kPa)	Not required	Not required	$\geq 16,0$
Microbial cleanliness (cfu/g)	≤ 30	≤ 30	≤ 30

^a Type I medical face masks should only be used for patients and other persons to reduce the risk of spread of infections particularly in epidemic or pandemic situations. Type I masks are not intended for use by healthcare professionals in an operating room or in other medical settings with similar requirements.

6 Marking, labelling and packaging

Annex I, §13, of the Medical Devices Directive (93/42/EEC) or Annex I, §23, of the Medical Device Regulation (EU) 2017/745 specifies the information that should be specified on the packaging in which the medical face mask is supplied.

The following information shall be supplied:

- a) number of this European Standard;

b) type of mask (as indicated in Table 1).

EN ISO 15223-1:2016 and EN 1041:2008+A1:2013 should be considered.

Annex A (informative)

Information for users

When breathing, speaking, coughing, sneezing, etc., one releases smaller or larger amounts of droplets of secretions from the mucous membranes in the mouth and nose. The majority of the nuclei are between 0,5 μm and 12 μm in diameter and especially the larger droplets can contain microorganisms from the source site. Nuclei can subsequently spread through the air to a susceptible site such as an open operating wound or sterile equipment.

The medical face masks intended to be used in operating rooms and health care settings with similar requirements are designed to protect the entire working environment. This standard describes two types of medical face masks with associated protection levels. As a minimum, Type I medical face masks are used for patients in order to reduce the risk of the spread of infections, particularly in epidemic or pandemic situations. Type II masks are principally intended for use by healthcare professionals in an operating room or other medical settings with similar requirements.

A special case, also covered by the European Medical Devices legislation, is that in which the wearer wishes to protect him/herself against splashes of potentially contaminated fluids.

If the intended use of the mask is to protect the wearer against infective agents (bacteria, viruses or fungi), the use of a respirator device is applicable in accordance with the Personal Protective Equipment (PPE) Directive (89/686/EEC) or the Personal Protective Equipment (PPE) Regulation (EU) 2016/425. Performance requirements for respirators are the scope of EN 149.

The level of efficiency offered by a mask depends on a number of factors such as the filtration efficiency, quality of the material and the fit of the mask on the wearer's face. Different designs are suited for different applications and the careful choice of mask is therefore important in order to achieve the desired result.

The filtration capacity of mask materials can vary depending on the filter media. The fit of masks varies considerably from those which are held in place by ear loops fastened behind the wearer's ears to those with tie bands around the head and a nose clamp that can be shaped to the wearer's nose.

It is usual to characterize mask performance using *in vitro* tests of the material from which the mask is made. It is, however, important to consider the fit of the mask carefully when a mask for a certain application is chosen.

A further factor to be considered is the capacity of the mask to absorb moisture from the exhaled air and thereby to maintain its performance over a longer period of time. The more advanced designs easily maintain their performance throughout even very long operations whereas the less advanced ones are intended only for short procedures.

Due to the fact that used masks are considered highly contaminated, it is essential that:

- the body of the mask is not touched by the fingers/hands of the wearer;
- hands are disinfected (full hand disinfection) after mask removal;
- a mask is worn covering the nose and mouth of the wearer, at no time a mask is hanging around the neck of the wearer;
- a used mask should be disposed of when no longer needed or between two procedures; when there is a further need for protection a new mask should be put on.

Annex B (normative)

Method for *in vitro* determination of bacterial filtration efficiency (BFE)

B.1 General

WARNING — *Staphylococcus aureus* is a pathogen. The relevant national provisions by law and hygienic instructions when dealing with pathogens shall be complied with.

B.2 Principle

A specimen of the mask material is clamped between a six-stage cascade impactor and an aerosol chamber. An aerosol of *Staphylococcus aureus* is introduced into the aerosol chamber and drawn through the mask material and the impactor under vacuum. The bacterial filtration efficiency (BFE) of the mask is given by the number of colony forming units passing through the medical face mask material expressed as a percentage of the number of colony forming units present in the challenge aerosol. For test apparatus see Figure B.3.

B.3 Reagents and materials

B.3.1 General

B.3.2 and B.3.3 describe commercially available solutions of tryptic soy agar and tryptic soy broth. Other variants may be suitable.

B.3.2 Tryptic soy agar

Formula/litre

Enzymatic digest of casein	15 g
Enzymatic digest of soybean meal	5 g
Sodium chloride	5 g
Agar	15 g
Final pH	7,3 ± 0,2 at 25 °C

B.3.3 Tryptic soy broth

Formula/litre

Enzymatic digest of casein	17 g
Enzymatic digest of soybean meal	3 g
Sodium chloride	5 g
Dipotassium phosphate	2,5 g
Dextrose	2,5 g
Final pH	7,3 ± 0,2 at 25 °C

B.3.4 Peptone water

Formula/litre

Peptone	10 g
Sodium chloride	5 g
Final pH	7,2 ± 0,2 at 25 °C

B.3.5 Culture of *Staphylococcus aureus* ATCC 6538, growing on tryptic soy agar slants.

B.4 Test apparatus

B.4.1 Six stage cascade impactor, the arrangement is specified in Table B.1.

B.4.2 Nebulizer, capable of delivering particles with a mean size of $(3,0 \pm 0,3)$ µm when in contact with the cascade impactor.

B.4.3 Aerosol chamber, glass, 600 mm long and 80 mm in external diameter.

B.4.4 Flow meters, capable of measuring a flow rate of 28,3 l/min.

B.4.5 Pressure gauge, capable of measuring a pressure of 35 kPa to an accuracy of ± 1 kPa.

B.4.6 Erlenmeyer flasks, 250 ml and 500 ml capacity.

B.4.7 Peristaltic or syringe pump, capable of delivering 0,01 ml/min.

B.4.8 Vacuum pump, capable of maintaining a flow rate of 57 l/min.

B.5 Test specimens

Test specimens shall be cut from complete masks. A complete mask may be used in place of a cut specimen, as long as the extremities are removed, the mask is laid flat and all layers are incorporated (in case of folded masks unfold the mask in order to test a surface as flat as possible). Each specimen shall be minimum 100 mm × 100 mm and shall include all layers of the mask in the order in which they are placed in the complete mask. The number of specimens that shall be tested is minimum 5, but can be greater and shall be increased if necessary to allow for an AQL (Acceptable Quality Level) of 4 %. All specimens tested shall be taken from representative areas to incorporate all/any variation in construction. Unless otherwise specified, the testing shall be performed with the inside of the medical face mask in contact with the bacterial challenge.

Each test specimen shall be conditioned at (21 ± 5) °C and (85 ± 5) % relative humidity for a minimum of 4 h to bring them into equilibrium with atmosphere prior to testing.

B.6 Preparation of bacterial challenge

Staphylococcus aureus (see B.3.5) shall be inoculated into 30 ml tryptic soy broth in an Erlenmeyer flask and incubated with mild shaking at a temperature of (37 ± 2) °C for (24 ± 2) h. The culture shall then be diluted in peptone water to give a concentration of approximately 5×10^5 CFU/ml.

The bacterial challenge shall be maintained at $1,7 \times 10^3$ to $3,0 \times 10^3$ CFU per test. The bacterial challenge shall be determined on the basis of experience and previous positive control plates (see B.7.3)

and the dilution of the challenge suspension adjusted accordingly. The mean particle size (MPS) in the bacterial challenge shall be maintained at $(3,0 \pm 0,3) \mu\text{m}$ (see B.7.9).

Table B.1 — Cascade impactor stage arrangement

Stage number	1	2	3	4	5	6
Size of particle	P1	P2	P3	P4	P5	P6
Viable “particle” plate count	C1	C2	C3	C4	C5	C6

where

$$P1 = 7,00 \mu\text{m}$$

$$P2 = 4,70 \mu\text{m}$$

$$P3 = 3,30 \mu\text{m}$$

$$P4 = 2,10 \mu\text{m}$$

$$P5 = 1,10 \mu\text{m}$$

$$P6 = 0,65 \mu\text{m}$$

$$MPS = \frac{(P1 \times C1) + (P2 \times C2) + (P3 \times C3) + (P4 \times C4) + (P5 \times C5) + (P6 \times C6)}{C1 + C2 + C3 + C4 + C5 + C6} \quad (\text{B.1})$$

The viable “particles” plate count values used for MPS calculations are the converted “probable hit” counts calculated using the positive hole conversion chart from the cascade impactor manual.

The MPS value above is the 50 % effective cut-off diameter calculated for each stage using the equation and information from the cascade compactor manual.

B.7 Procedure

B.7.1 Assemble the test apparatus in accordance with the flow chart shown in Figure B.1 or Figure B.3.

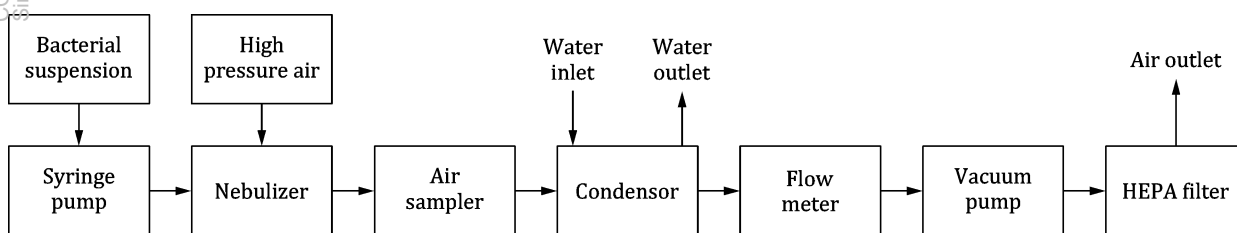

Figure B.1 — Principle of BFE test apparatus

B.7.2 Deliver the bacterial challenge to the nebulizer using the peristaltic or syringe pump.

B.7.3 Perform a positive control run without a test specimen. Initiate the bacterial challenge by turning on the vacuum pump and adjust the flow rate through the cascade impactor to 28,3 l/min. Deliver the bacterial challenge for 1 min. Maintain the airflow through the cascade impactor one additional minute (total test time is 2 min). Then remove the plates from the cascade impactor. Ensure that each plate is numbered to indicate its position in the cascade impactor.

B.7.4 Place fresh plates in the cascade impactor, clamp the test specimen in place between the first stage of the cascade impactor and the inlet cone (see Figure B.2) and repeat the procedure described in

B.7.3. **AC** The test area shall be minimum 49 cm^2 **AC**. Alternative means to position the sample may be appropriate, but, if deviated from the procedure, this shall be documented in the test report.

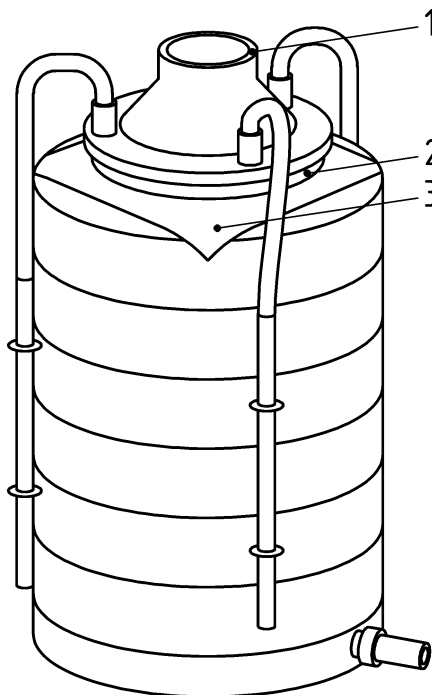

Key

- 1 inlet cone
- 2 o'ring inlet cone
- 3 cloth / mask

Figure B.2 — Placement of test specimen on the cascade impactor

B.7.5 Repeat this procedure for each test specimen.

B.7.6 After the last test specimen has been tested, perform a further positive control run.

B.7.7 Perform a negative control run by passing air, without addition of the bacterial challenge, through the cascade impactor for 2 min.

B.7.8 Incubate all the plates at $(37 \pm 2) \text{ }^\circ\text{C}$ for (20 to 52) h.

B.7.9 For each specimen and control run, count the number of colonies on each plate and add up the counts to give the total number of CFU collected by the cascade impactor. Use the “positive hole” conversion table¹⁾ in accordance with the instructions of the cascade impactor manufacturer for stages 3 to 6. For the two positive control runs, take the mean of the two totals. From the positive control plates calculate the mean particle size (MPS) of bacterial challenge aerosol using the formula given in B.6.

B.8 Calculation of bacterial filtration efficiency (BFE)

For each test specimen calculate the bacterial filtration efficiency B , as a percentage, using the following formula:

1) See the positive hole conversion table found in the cascade impactor manual.

$$B = (C - T) / C \times 100 \quad (\text{B.2})$$

where

- C is the mean of the total plate counts for the two positive control runs;
- T is the total plate count for the test specimen.

B.9 Test report

The following information shall be given in the test report:

- a) number and date of this European Standard;
- b) lot number or batch code of the masks tested;
- c) dimensions of the test specimens and the size of the area tested;
- d) which side of the test specimen was facing towards the challenge aerosol;
- e) flow rate during testing;
- f) mean of the total plate counts of the two positive controls;
- g) mean plate count of the negative controls;
- h) bacterial filtration efficiency (BFE) for each test specimen.

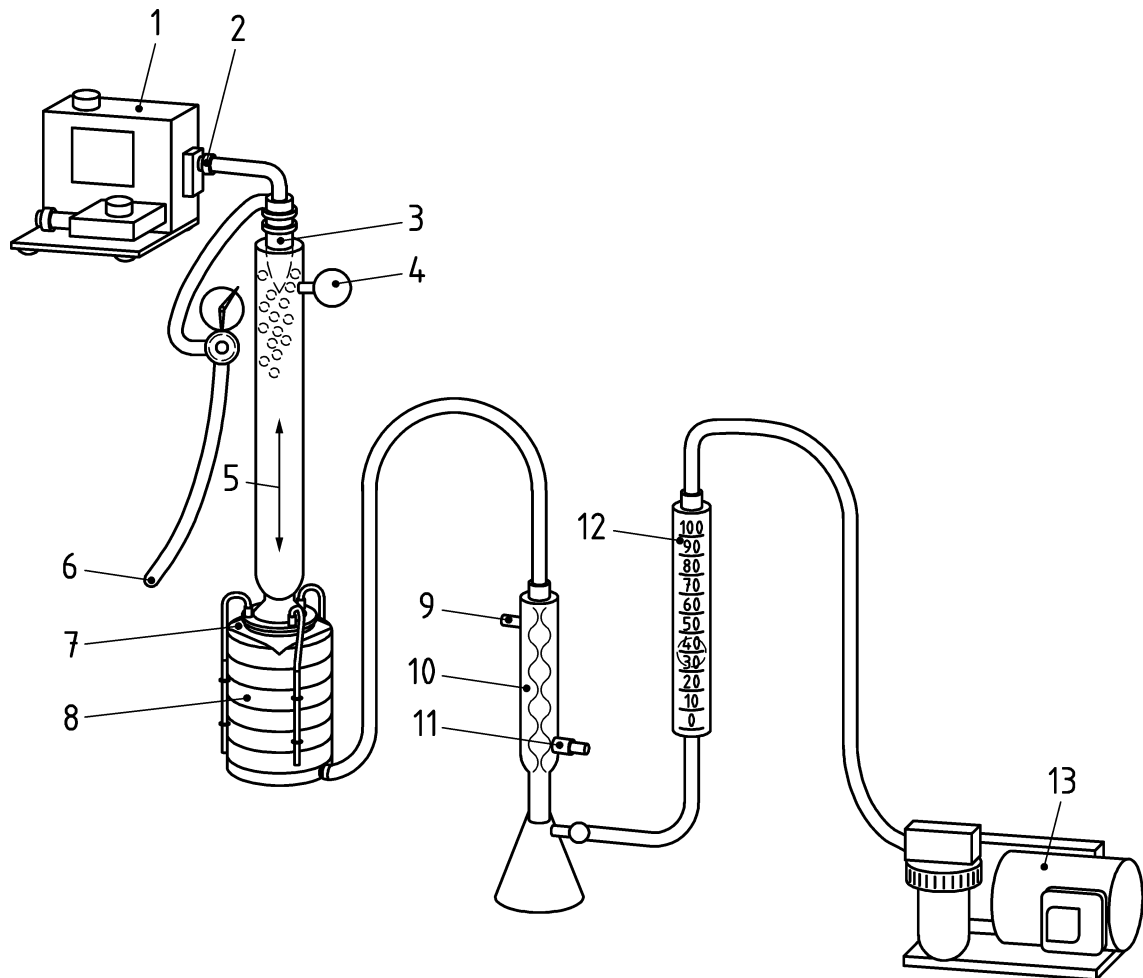

Key

- | | | | |
|---|--------------------------|----|--------------------------|
| 1 | drive mechanism | 8 | cascade impactor |
| 2 | bacterial suspension | 9 | outlet to sink |
| 3 | nebulizer | 10 | condenser |
| 4 | filter | 11 | cold water inlet |
| 5 | aerosol chamber | 12 | calibrated flow meter |
| 6 | high pressure air source | 13 | compressor (vacuum pump) |
| 7 | test material | | |

Figure B.3 — Example of real BFE test apparatus

Annex C (normative)

Method for determination of breathability (differential pressure)

C.1 Principle

A device which measures the differential pressure required to draw air through a measured surface area at a constant air flow rate is used to measure the air exchange pressure of the medical face mask material, as shown in Figure C.1. A water-filled (or digital) differential manometer is used to measure the differential pressure. A mass flow meter is used for measurement of the airflow. An electric vacuum pump draws air through the test apparatus and a needle valve is used to adjust the airflow rate.

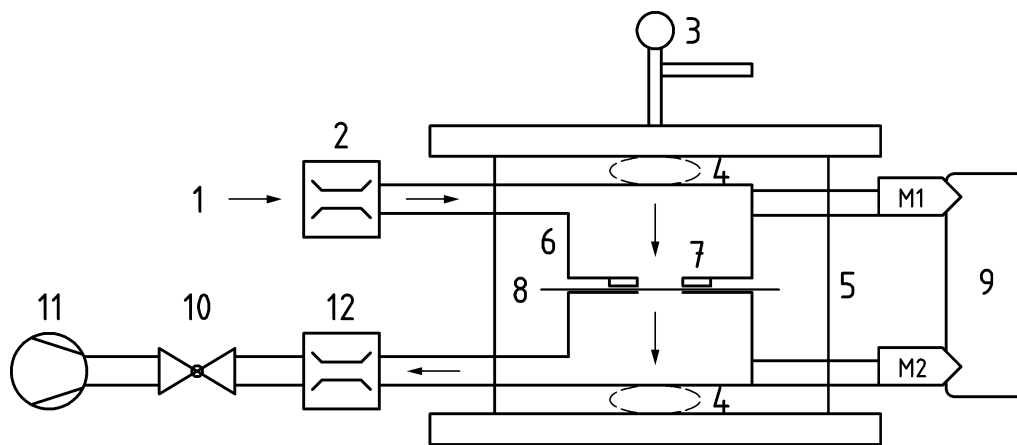

Key

- | | | | |
|---|---|----|--|
| 1 | air inlet | 7 | metallic ring (3 mm thick) |
| 2 | mass flow meter | 8 | filter material |
| 3 | lever for mechanical clamping | 9 | differential manometer or M1 and M2 manometers |
| 4 | system for final adjustment of the pressure (either at the top or the bottom) | 10 | valve |
| 5 | system ensuring optimal alignment of the 2 parts of the sample holder | 11 | vacuum pump including a pressure buffer tank |
| 6 | sample holder with a metal sealing mechanism | 12 | mass flow meter for checking leaks (optional) |

Figure C.1 — Test apparatus for measuring differential pressure

C.2 Test apparatus

C.2.1 Mass flow meter(s) capable of measuring an airflow of 8 l/min.

C.2.2 Manometer, a differential manometer (water or digital). Individual manometers can also be used. M1 is for the upstream pressure measurement and M2 is for the downstream pressure measurement.

C.2.3 Electric vacuum pump including a pressure buffer tank.

C.2.4 Valve permitting the adjustment of the flow rate.

C.2.5 Sample holder

C.2.5.1 The sample holder shall consist of a mechanical clamping system and alignment of the top and bottom holder.

C.2.5.2 The sample holder shall consist of a mechanism to adjust the clamping pressure. A system with thread of screw can be used either at the bottom or top part of the sample holder.

C.2.5.3 The internal diameter of the top holder and the bottom holder in the contact area with the filter material shall be (25 ± 1) mm.

C.2.5.4 The seal of the top and bottom holder onto the filter material shall consist of a metal-metal contact.

A metallic ring of internal diameter of (25 ± 1) mm and ca. 3 mm thick will be fixed to the top holder. The bottom holder will consist of a completely flat metallic surface with an internal diameter of (25 ± 1) mm and a 3 mm area around the open diameter. Materials such as rubber or poly foam do not provide a sufficient seal and may deform into the test area.

C.2.5.5 Validation of the test apparatus shall consist of a leak test. A second flow meter (12) placed immediately before the valve (10) will allow for evaluation of an air leak within the test apparatus. With the sample holder closed, start the pump and adjust the flow meter to read 8 l/min on the first flow meter (2). If no leaks are present both flow meters should read 8 l/min.

Another check shall consist of stopping inlet air when both flow meters give 8 l/min. After a few seconds both flow meters should indicate 0 l/min if no leaks.

C.3 Test specimens

Test specimens are complete masks or shall be cut from complete masks. If a complete mask is used, remove extremities and lay the mask flat with all layers incorporated. Each specimen shall be able to provide different circular test areas of 25 mm in diameter. If one specimen cannot provide 5 test areas of 25 mm diameter, the number of test areas retrieved should be representative for the entire mask. For thick and rigid masks the test method may not be suitable as a proper seal cannot be maintained in the sample holder. The number of specimens that shall be tested is minimum 5, but can be greater and shall be increased if necessary to allow for an AQL of 4 %. All specimens tested shall be taken from areas representative from the mask to incorporate all/any variation in construction. Unless otherwise specified, the testing shall be performed with the airflow direction from the inside of the mask to the outside of the mask.

Each test specimen shall be conditioned at (21 ± 5) °C and (85 ± 5) % relative humidity for a minimum of 4 h.

C.4 Procedure

C.4.1 Without a specimen in place, the holder is closed and the differential manometer is zeroed. The pump is started and the flow of air adjusted to 8 l/min.

C.4.2 The holder is opened and the test specimen is placed across the 25 mm diameter orifice (total area 4,9 cm²) between the top and bottom parts of the holder. Then it is clamped in place using a mechanical clamp with sufficient pressure to avoid air leaks. Due to the presence of an alignment system the tested area of the specimen should be perfectly in line and across the flow of air.

With the specimen in place the flow rate should be 8 l/min as previously set in C.4.1. If the flow rate is not at 8 l/min, a leak may be present. Try to increase the pressure if possible to avoid this problem. In such case the use of a second flow meter during testing is also indicated.

C.4.3 The differential pressure is read directly if using a differential pressure manometer. If using manometers M1 and M2 read and record each pressure.

C.4.4 The procedure described in steps C.4.1 to C.4.3 is carried out on 5 (or appropriate number) different areas of the mask and the readings averaged.

If the mask comprises different material types in different areas, test an even number of the different areas. For example, the average should consist of 3 readings on the top portion of the mask with material type A and 3 readings on the bottom portion of the mask with material type B.

C.5 Calculation of differential pressure

For each test specimen calculate the differential pressure $\Delta P/\text{cm}^2$ of each tested area as follows:

$$\Delta P = (X_{m1} - X_{m2})/4,9 \quad (\text{C.1})$$

where

X_{m1} is the pressure in Pa, measured by manometer M1 – low pressure side of the material;

X_{m2} is the pressure in Pa, measured by manometer M2 – high pressure side of the material;

4,9 is the area (in cm²) of the test material;

ΔP is the differential pressure per cm² of test material expressed in Pa.

NOTE If a differential manometer is used the differential pressure ($X_{m1} - X_{m2}$) is directly obtained.

C.6 Test report

The following information shall be given in the test report:

- a) number and date of this European Standard;
- b) lot number or batch code and description of the masks tested;
- c) number and general location of the areas of the mask the differential measurements were taken;
- d) flow rate during testing;
- e) differential pressure for each tested area of the test specimen and the average value for each test specimen. The average value for each test specimen is used to determine the final classification of the mask.

Annex D (informative)

Microbial cleanliness

D.1 Sampling

Mask samples for testing should be provided in the original primary packaging (dispenser box or equivalent) as offered to the end user. When 5 samples are selected take the top, bottom and 3 randomly chosen masks. If the mask contains a visor or other accessories it should be included in the testing.

D.2 Testing

Weigh each mask prior testing. The full mask is aseptically removed from the packaging and placed in a sterile 500 ml bottle containing 300 ml of extraction liquid (1 g/l Peptone, 5 g/l NaCl and 2 g/l polysorbate surfactant 20 [e.g. Tween 20, Alkest TW 20]).

The bottle is laid down on an orbital shaker and shaken for 5 min at 250 rpm. After this extraction step, 100 ml of the extraction liquid is filtered through a 0,45 µm filter and laid down on a TSA plate for the total viable aerobic microbial count. Another 100 ml aliquot of the same extraction liquid is filtered in the same way and the filter plated on Sabouraud Dextrose agar (SDA) with chloramphenicol for fungi enumeration. The plates are incubated for 3 days at 30 °C and 7 days at (20 to 25) °C for TSA and SDA plates respectively. An alternative and equivalent extraction method may be used. If this is the case, the chosen extraction method shall be documented in the test report.

The total bioburden is expressed by addition of the TSA and SDA counts.

Annex ZA (informative)

Relationship between this European Standard and the essential requirements of Directive 93/42/EEC [1993 OJ L 169] aimed to be covered

This European Standard has been prepared under a Commission's standardization request 'M/295 concerning the development of European Standards related to medical devices' to provide one voluntary means of conforming to essential requirements of Council Directive 93/42/EEC of 14 June 1993 concerning medical devices [1993 OJ L 169].

Once this standard is cited in the Official Journal of the European Union under that Directive, compliance with the normative clauses of this standard given in Table ZA.1 confers, within the limits of the scope of this standard, a presumption of conformity with the corresponding essential requirements of that Directive, and associated EFTA regulations.

NOTE 1 Where a reference from a clause of this standard to the risk management process is made, the risk management process needs to be in compliance with Directive 93/42/EEC as amended by 2007/47/EC. This means that risks have to be reduced 'as far as possible', 'to a minimum', 'to the lowest possible level', 'minimized' or 'removed', according to the wording of the corresponding essential requirement.

NOTE 2 The manufacturer's policy for determining **acceptable risk** must be in compliance with Essential Requirements 1, 2, 5, 6, 7, 8, 9, 11 and 12 of the Directive.

NOTE 3 When an Essential Requirement does not appear in Table ZA.1, it means that it is not addressed by this European Standard.

Table ZA.1 — Correspondence between this European Standard and Annex I of Directive 93/42/EEC [1993 OJ L 169]

Essential Requirements of Directive 93/42/EEC	Clause(s) / sub-clause(s) of this EN	Remarks / Notes
3.1, first sentence only	5.1.1, 5.1.2, 5.2.2, 5.2.4, 5.2.5, 5.2.6	Covered in respect of: <ul style="list-style-type: none"> - integrity during use; - provision of a means for a close fit; - bacterial filtration efficiency; - splash resistance, where applicable; - microbial cleanliness (bioburden). Design of the manufacturing process is not covered.

WARNING 1 — Presumption of conformity stays valid only as long as a reference to this European Standard is maintained in the list published in the Official Journal of the European Union. Users of this standard should consult frequently the latest list published in the Official Journal of the European Union.

WARNING 2 — Other Union legislation may be applicable to the product(s) falling within the scope of this standard.

Bibliography

- [1] EN 132, *Respiratory protective devices — Definitions of terms and pictograms*
- [2] EN 149, *Respiratory protective devices — Filtering half masks to protect against particles — Requirements, testing, marking*
- [3] EN 1041:2008+A1:2013, *Information supplied by the manufacturer of medical devices*
- [4] EN 1174 (all parts), *Sterilization of medical devices — Estimation of the population of micro-organisms on product*
- [5] EN ISO 15223-1:2016, *Medical devices — Symbols to be used with medical device labels, labelling and information to be supplied — Part 1: General requirements (ISO 15223-1:2016, Corrected version 2017-03)*
- [6] EN ISO 139, *Textiles — Standard atmospheres for conditioning and testing (ISO 139)*
- [7] 93/42/EEC Council Directive 93/42/EEC of 14 June 1993 concerning medical devices as amended by Directive 2007/47/EC of the European Parliament and of the Council of 5 September 2007
- [8] EN ISO 10993 series, *Biological evaluation of medical devices (ISO 10993 series)*

Licensed by ADVISERA TO RWANDA STANDARDS BOARD
COPY FOR REFERENCE PURPOSE ONLY; DOWNLOADED 2020-04-09
Single-User license only. Copying and Networking prohibited

standard@evs.ee

www.evs.ee